

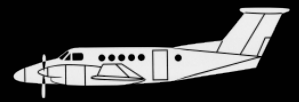

Globe Trotter
Seat by 

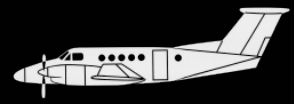



*Attention
to detail*



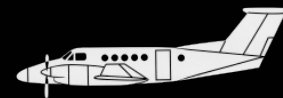

GlobeTrotter GT Seat Details

Description: The all-new GlobeTrotter GT seat was designed to provide maximum executive comfort while maintaining AvFab's tradition for robust, lightweight, high density King Air seating. Optional dual armrests are unique to the GlobeTrotter GT. Delivered in "green" condition, without upholstery (upholstery is optional). It is important to note that we have never had a request for a spare part or repair for any of our high density series of seats, so they are extremely durable.

Features: AvFab's GlobeTrotter Seat (GT) is engineered for lightweight durability and affordability, with elements that make it conducive to maximum high density applications. It was designed to enhance the ease of occupant ingress and egress, by increasing leg, knee, foot room, and passenger comfort. It is best-suited for applications where maximum seating is desired. Seat features forward folding back and includes lap belt, life vest pouch, and cushions (un-upholstered). Various floor plans are available for both forward and aft-facing Traveler Seats.

Installation: No airframe modification is required other than removing existing seats and furnishings, and sliding the new high density seats onto original seat rails (complete installation instructions, diagrams, and weight and balance information are included in the kit). On some models of the King Air, a table plug is recommended for aesthetic purposes. Upholstered GlobeTrotter GT seat weighs 27 lbs., Aft-Facing GlobeTrotter GT seat weighs 32lbs.

Approvals:	U.S. STC:	SA2774CE	200 & 300 (350) series
		SA2775CE	100 & 99 series
		SA2776CE	F90
		SA2777CE	65, 80, & 90 series
			300 (350) series only
	Canada:	C13-0259	200 & 300 (350) series
	EASA:	10032446	200 & 300 (350) series
	Mexico:	IA-294/2014	200 & 300 (350) series
	Nigeria:	P.M.B. 21029, 21038	200 & 300 (350) series
	Russia:	CT80-300	B300 (350) series

Options: Flush Folding Arm Rest inboard, Fixed Arm Rest outboard, Leather Upholstery

Lead Time: Seats are normally in stock and available for immediate world-wide shipment, however, fluctuations in demand may cause as much as a 30 day delay for delivery.





Globetrotter GT Seat Options

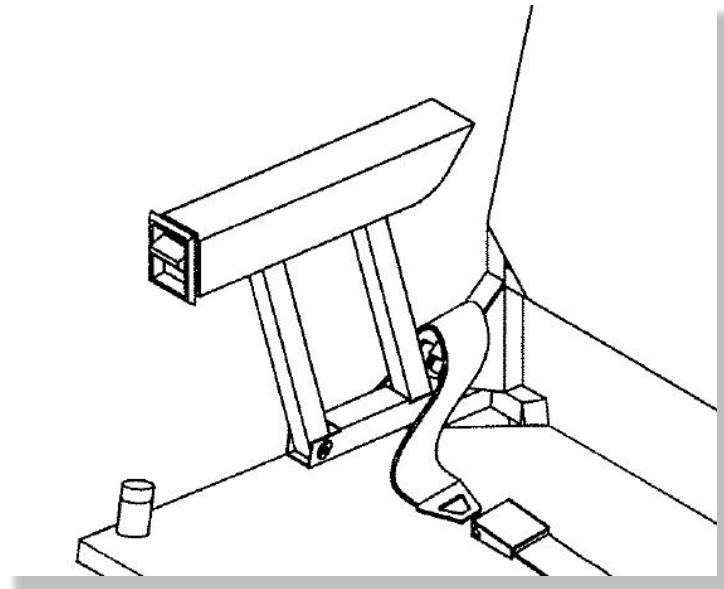

Here are some of the many
Leather Upholstery colors available...

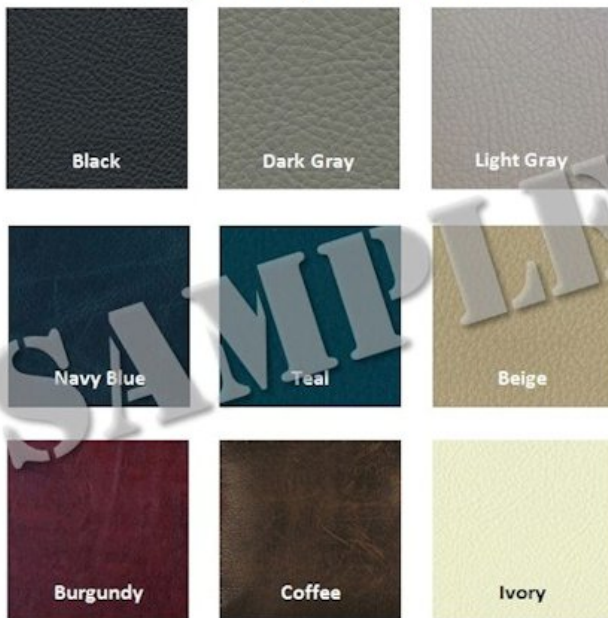

...more colors available upon request!







Globetrotter GT Seat Dimensions

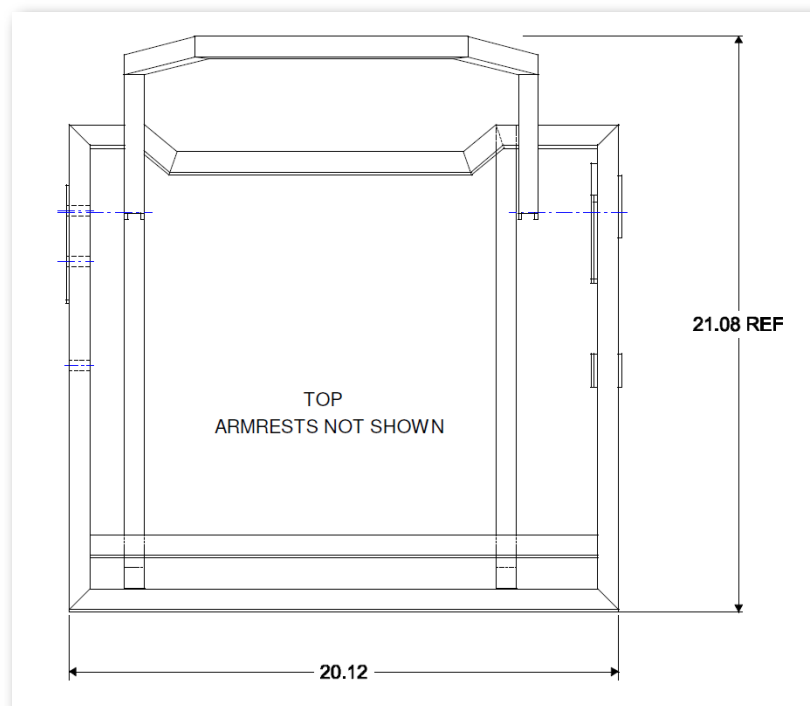
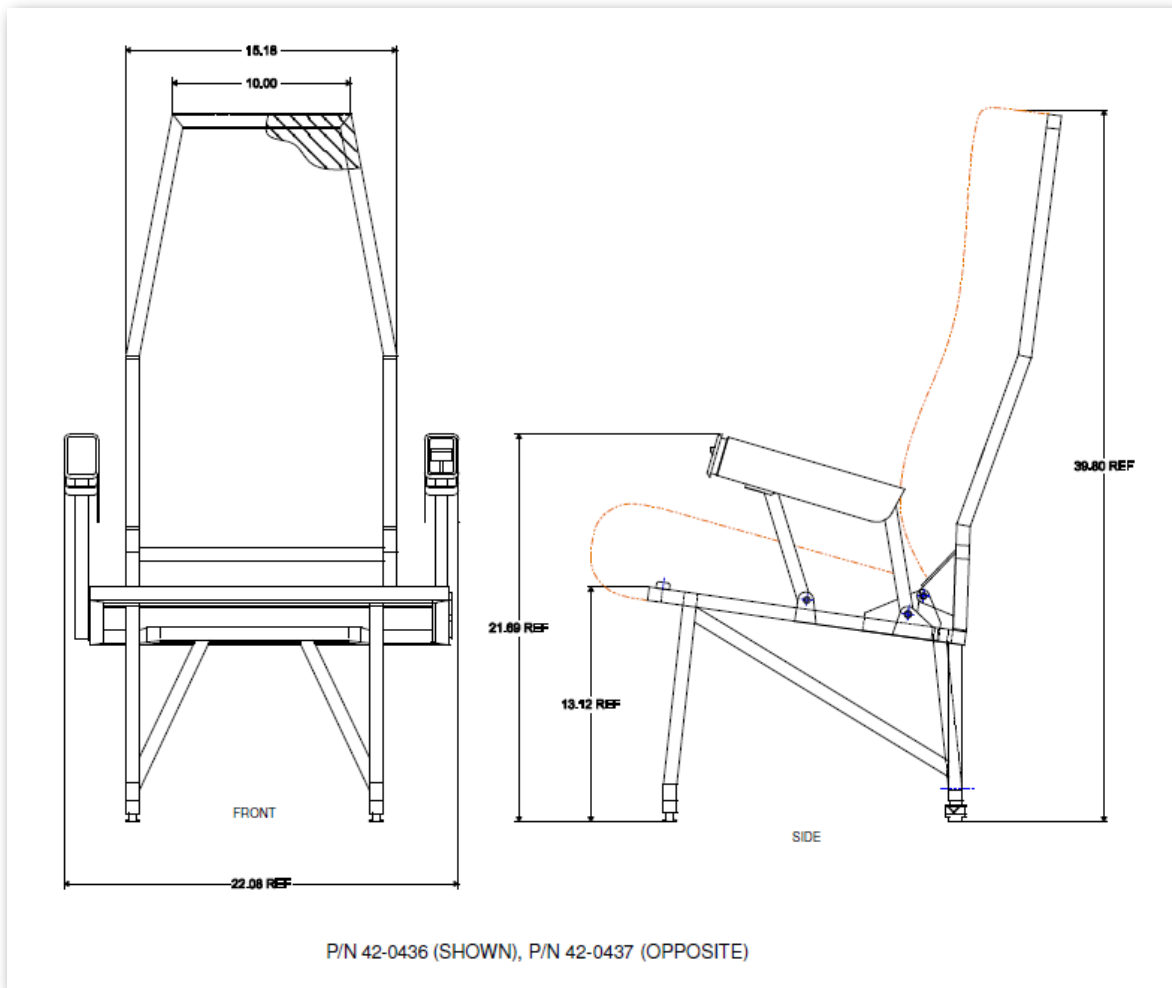

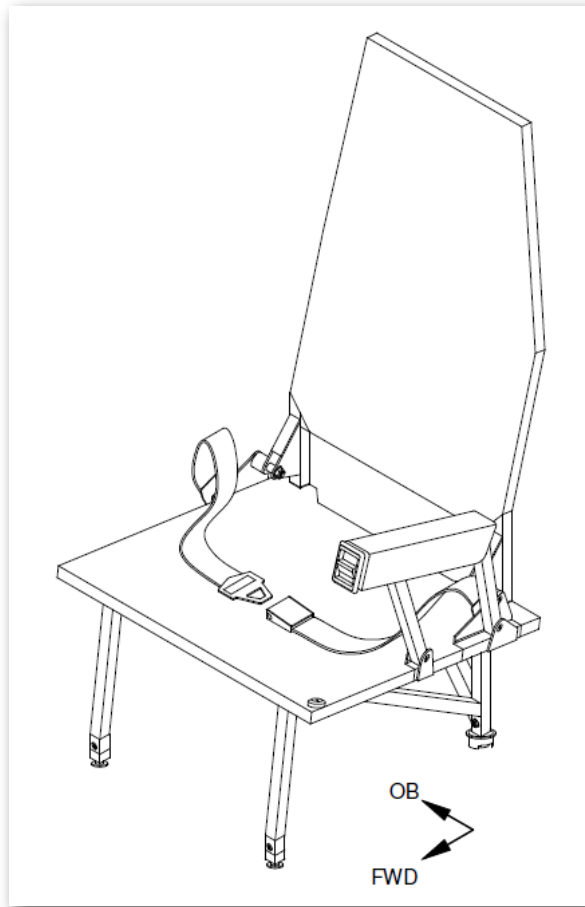
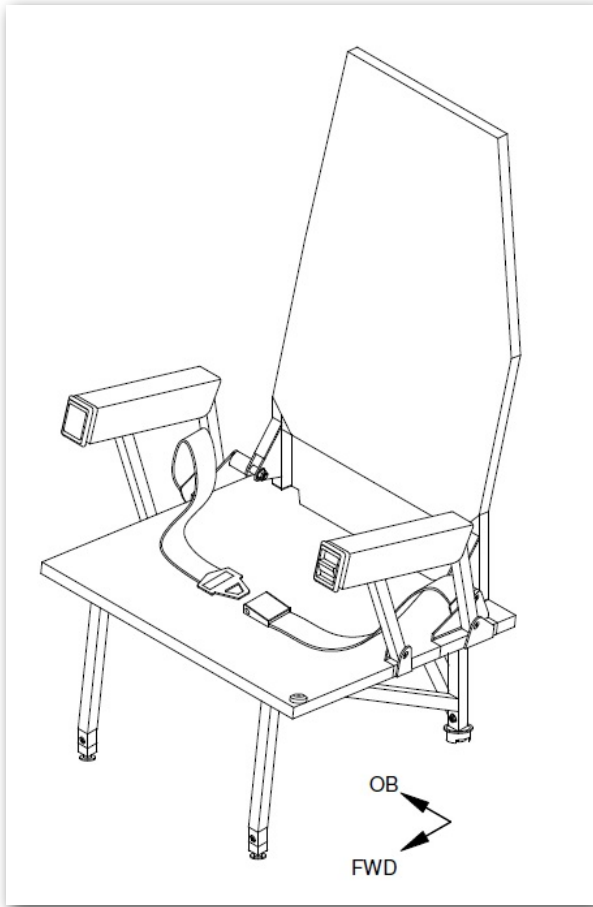
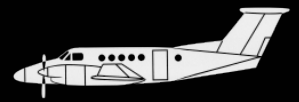

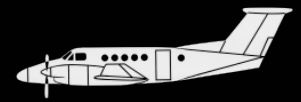

NEW!

Aft Facing Seat

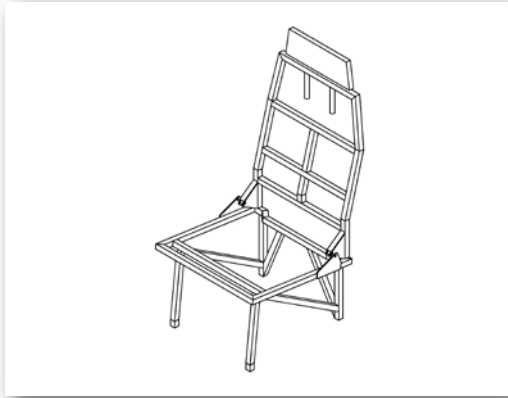

Robust frame design is now certified for Club seating floorplans!

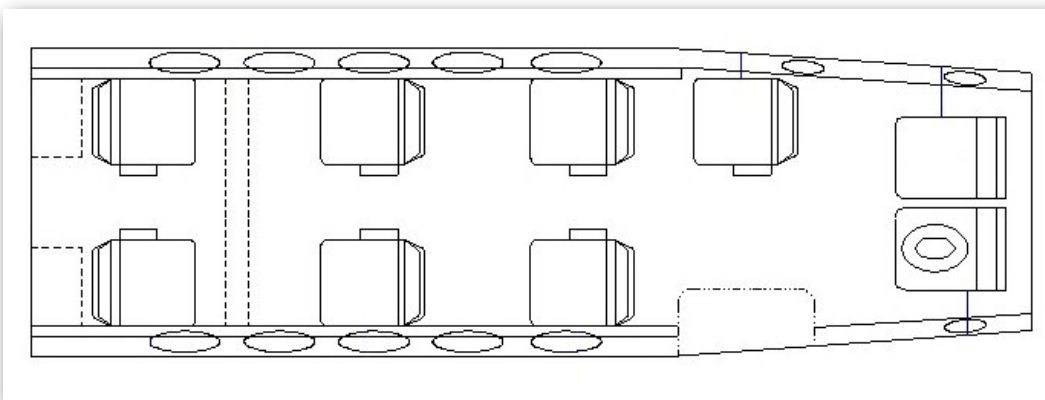



Sample *Globetrotter GT* Seat Floor Plans

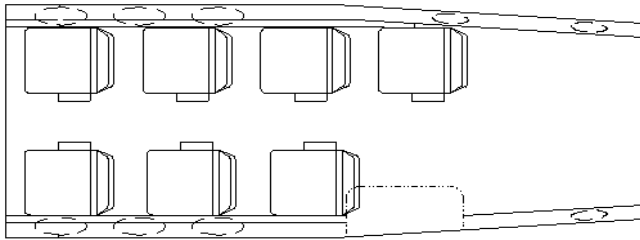

7 Passenger

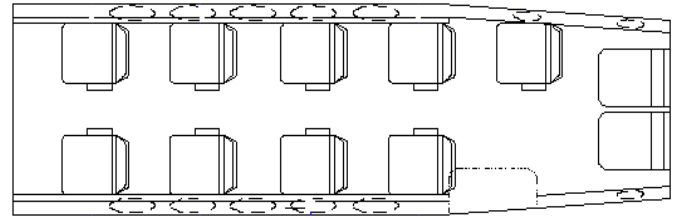

9 Passenger

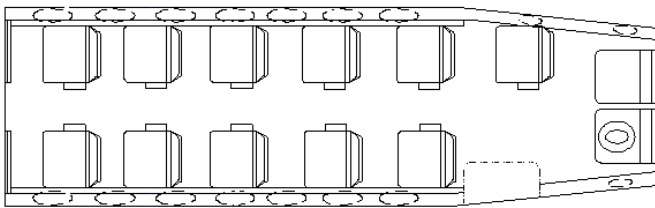

11 Passenger

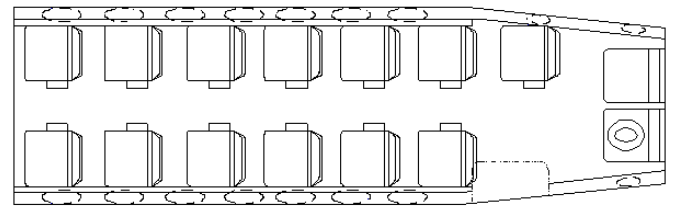

13 Passenger



King Air 90
5 Seat Floor Plan
Airline Style Seats



King Air 100, 200, 300
7 Seat Floor Plan
Airline Style Seats



King Air 100, 200, 300
9 Seat Floor Plan
Airline Style Seats



King Air 350
11 Seat Floor Plan
Airline Style Seats



King Air 350
13 Seat Floor Plan
Airline Style Seats



King Air 350i - Executive Interior

Weight Savings *Globetrotter GT* Seat – Double Club

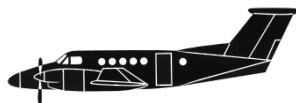

Typical OEM “Executive Seats”

8 X 55 lbs. ea. = 440 lbs.

Newest 350i seats weigh even more. 8 X 75 lbs. ea. = 600 lbs.

AvFab “Globetrotter” Seats

4 Forward facing X 27 lbs. ea. = 108 lbs.

4 Aft facing X 32 lbs. ea. = 128 lbs.

Total 236 lbs.

Weight Savings up to 364 lbs.!

King Air 250 - Executive Interior

Weight Savings *Globetrotter GT* – Club and a Half

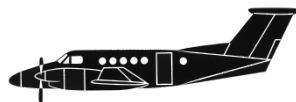

OEM “Executive Seats”

6 X 55 lbs. ea. = 330 lbs.

AvFab “Globetrotter” Seats

4 Forward facing X 27 lbs. ea. = 108 lbs.

2 Aft facing X 32 lbs. ea. = 64 lbs.

Total 172 lbs.

Weight Savings of 158 lbs.!





Learn more about Avfab's comprehensive line
of King Air products & services at
www.AvFab.com

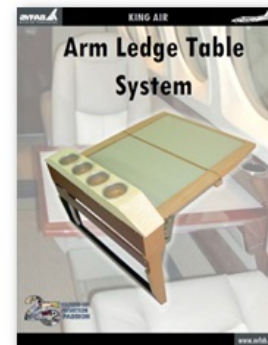
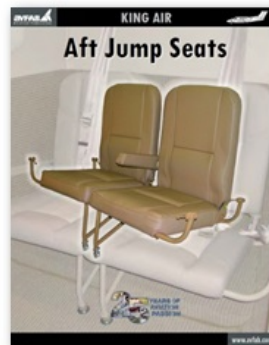

Aviation Fabricators
805 North 4th Street
Clinton, MO 64735
(666) 885-8317
www.AvFab.com

